

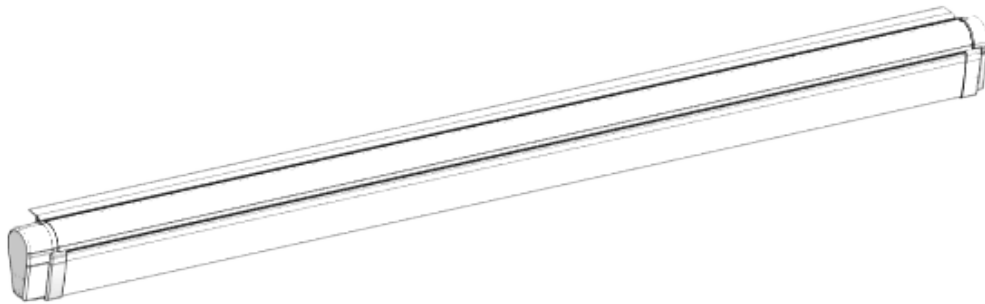

# ROOF & WALL MOUNT CASSETTE AWNING

USER MANUAL













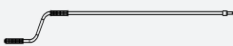

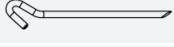



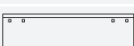



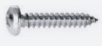

12V & MANUAL



Read this manual thoroughly.  
 Incorrect installation or operation may void any warranty.  
 Incorrect use or operation may cause serious injury.

## PARTS INCLUDED:

PARTS	2000mm	2500mm	3000mm	3500mm	4000mm	4500mm	5000mm
Cassette Awning 	x1	x1	x1	x1	x1	x1	x1
Installation Manual 	x1	x1	x1	x1	x1	x1	x1
User Manual 	x1	x1	x1	x1	x1	x1	x1
Crank Handle 	x1	x1	x1	x1	x1	x1	x1
Crank Handle Clip 	x2	x2	x2	x2	x2	x2	x2
Hook 	x4	x4	x4	x4	x4	x4	x4
65mm Bracket 	x1	x1	-	x2	-	-	-
110mm Bracket 	x2	x2	x3	-	x2	-	-
175mm Bracket 	-	-	-	x2	-	x2	-
400mm Bracket 	-	-	-	-	x2	x2	-
800mm Bracket 	-	-	-	-	-	-	x3
Mounting Bracket Kit 1 	x3	x3	x3	x3	x3	x4	x9
Mounting Bracket Kit 2 	x2	x2	x3	x5	x6	x8	x9
Support Leg Bracket 	x2	x2	x2	x2	x2	x2	x2
DIN603-M6x55 	x5	x5	x6	x10	x12	x16	x18
DIN965-M6x55 	x2	x2	x3	x3	x3	x4	x9
Stainless Steel Round Tap Rivet DIN7337-M4x21 	x4	x4	x4	x4	x4	x4	x4
DIN7981 ST4.2x25 	x8	x8	x8	x8	x8	x8	x8
DIN7981 ST4.2x8 	x6	x6	x6	x6	x8	x8	x8
DIN934-M6 	x7	x7	x9	x13	x15	x20	x20
DIN6798-M6 	x7	x7	x9	x13	x15	x20	x20
Motor Head 	x1	x1	x1	x1	x1	x1	x1
ST3.9x20 Self-tapping screws 	x2	x2	x2	x2	x2	x2	x2
ST3.9x38 Self-tapping screw 	x1	x1	x1	x1	x1	x1	x1
Trip Assistant Sticker 	x1	x1	x1	x1	x1	x1	x1

1300 663 868 | enquiries@aussietraveller.com.au | aussietraveller.com.au

BRISBANE SHOWROOM: 11-15 Oasis Court, Clontarf QLD 4019 | MELBOURNE SHOWROOM: 235 Barry Road, Campbellfield VIC 3061

# PRODUCT INTRODUCTION

The Aussie Traveller 12V & Manual Cassette awnings with wall and roof mount options.

Ask Aussie Traveller about the full range of awnings and accessories that are available.

## WALL MOUNT INSTALLATION

### CORRECT POSITIONING:

When installing the Aussie Traveller Cassette awning follow these instructions for correct installation of the cassette.

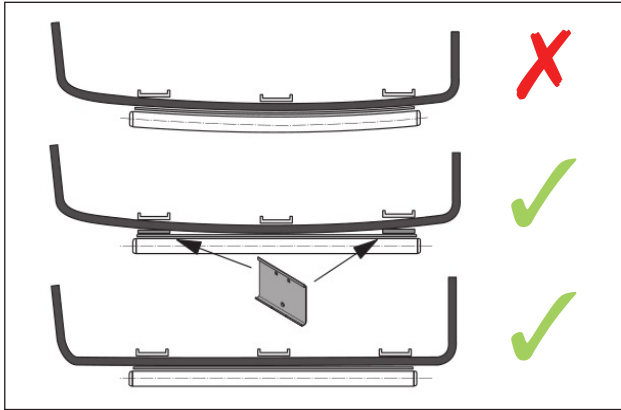

Ensure the ATRV Cassette awning is installed to a straight, flat side without any curve of the cassette itself.

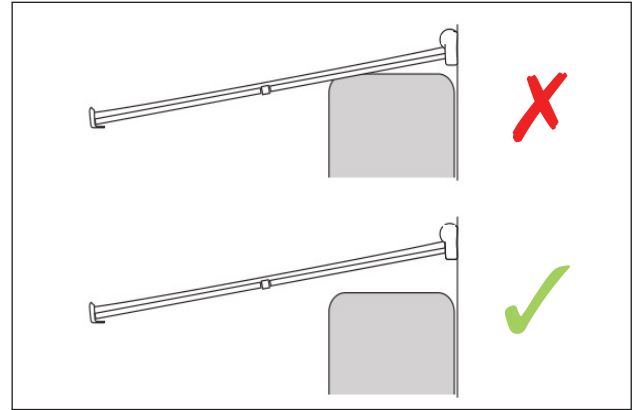

Ensure there is adequate (30cm) clearance from any opening; eg. doors.

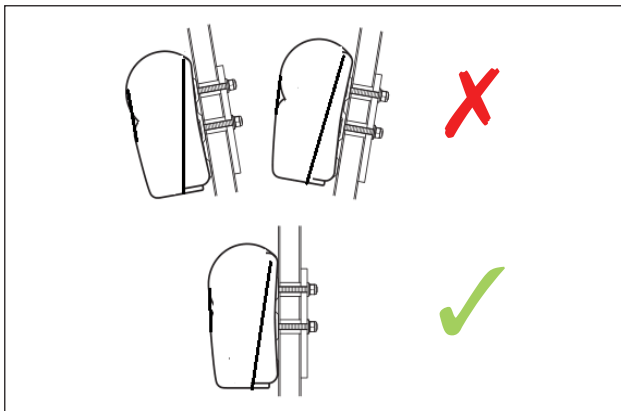

The awning bracket should be installed vertically and parallel to the vehicle; not on an angle.

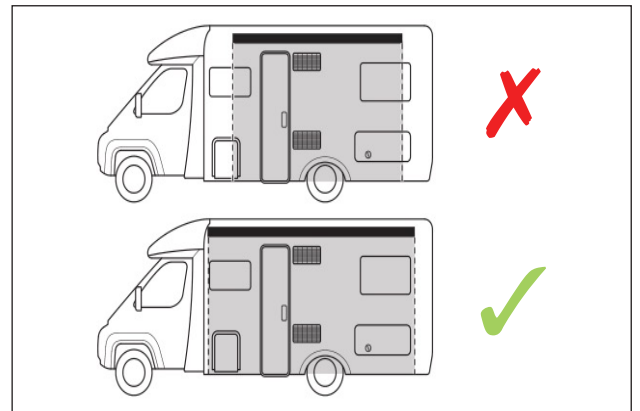

Install the awning towards the front of the vehicle.

1300 663 868 | [enquiries@aussietraveller.com.au](mailto:enquiries@aussietraveller.com.au) | [aussietraveller.com.au](http://aussietraveller.com.au)

BRISBANE SHOWROOM: 11-15 Oasis Court, Clontarf QLD 4019 | MELBOURNE SHOWROOM: 235 Barry Road, Campbellfield VIC 3061

# WALL MOUNT INSTALLATION (cont.)

## FIXED BRACKET MOUNTING:

Please refer to the below size guide for bracket placement.

To prepare for installing the awning, you will need:

- 1 × 3mm Drill Bit
- 1 × 6mm Drill Bit
- 1 × Power Drill
- 1 × Adjustable Spanner
- 1 × Phillips Head Screwdriver

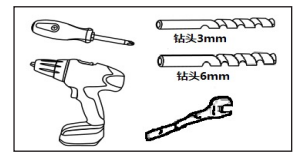

A. Tools required

For measuring out the mounting bracket drilling holes before drilling:

- 1 × Ruler
- 1 × Level
- 1 × Marker Pen

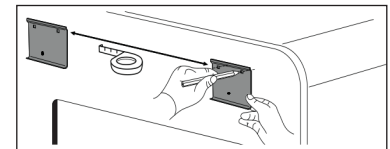

B. Mark the fixing point on the outer wall and drill, following the bracket.

## FIXED BRACKET MOUNTING GUIDE:

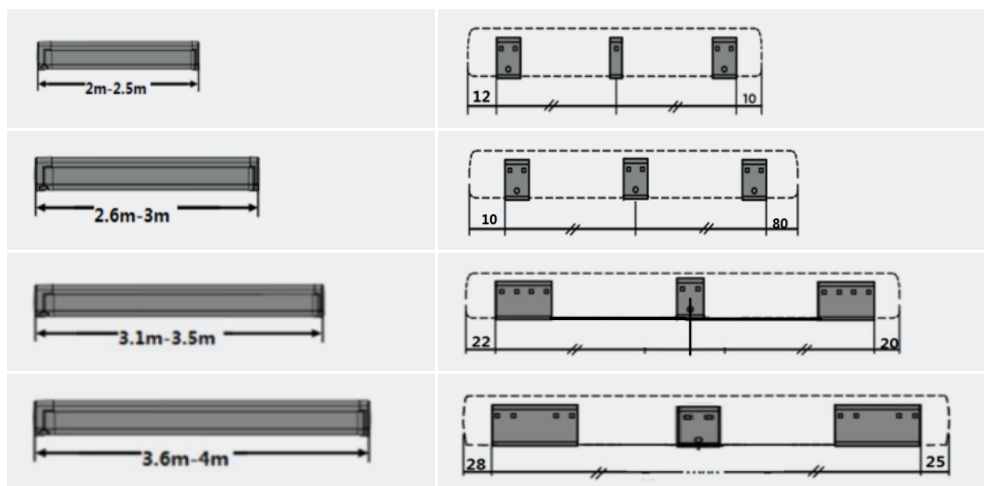

Please follow the diagrams when installing the Aussie Traveller Cassette Awning:

1. Measure and mark the holes. Fit bracket and screws to holes.
2. Screw the fastening bracket nut.
3. Install the awning to mounting bracket.
4. Screw in the fixing and tighten.

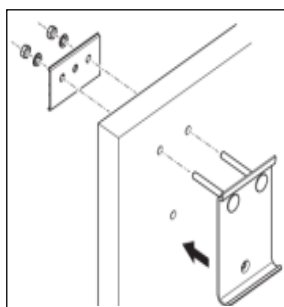

1.

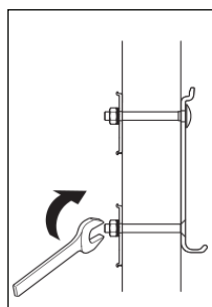

2.

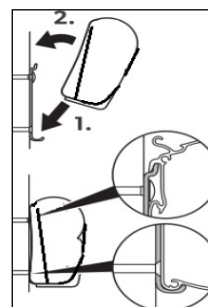

3.

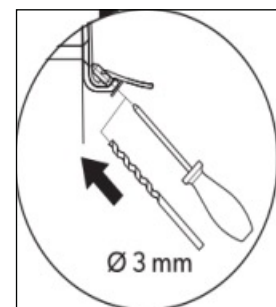

4.

1300 663 868 | [enquiries@aussietraveller.com.au](mailto:enquiries@aussietraveller.com.au) | [aussietraveller.com.au](http://aussietraveller.com.au)

BRISBANE SHOWROOM: 11-15 Oasis Court, Clontarf QLD 4019 | MELBOURNE SHOWROOM: 235 Barry Road, Campbellfield VIC 3061

# WALL MOUNT INSTALLATION (cont.)

## APPLICATION 1

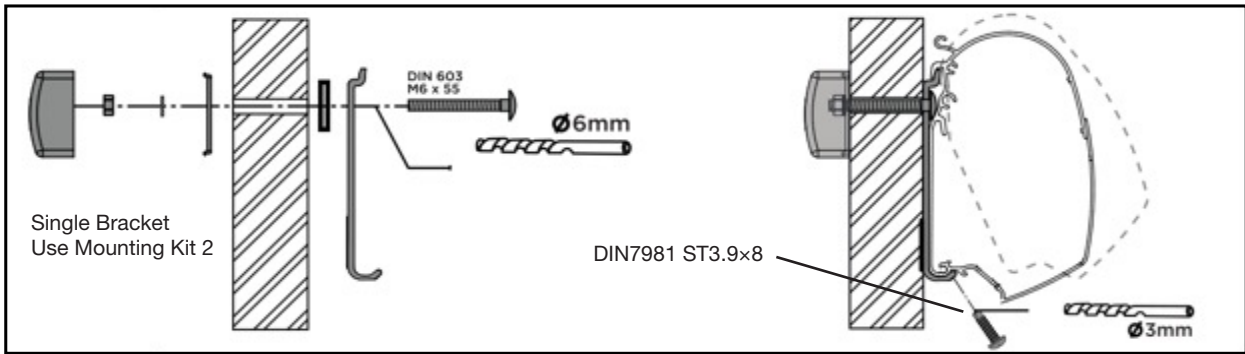

## APPLICATION 2

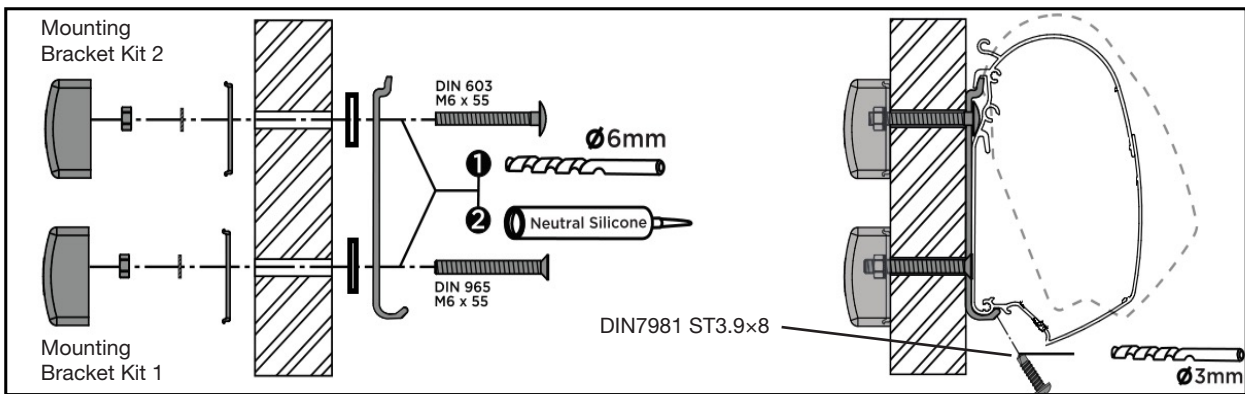

## APPLICATION 3

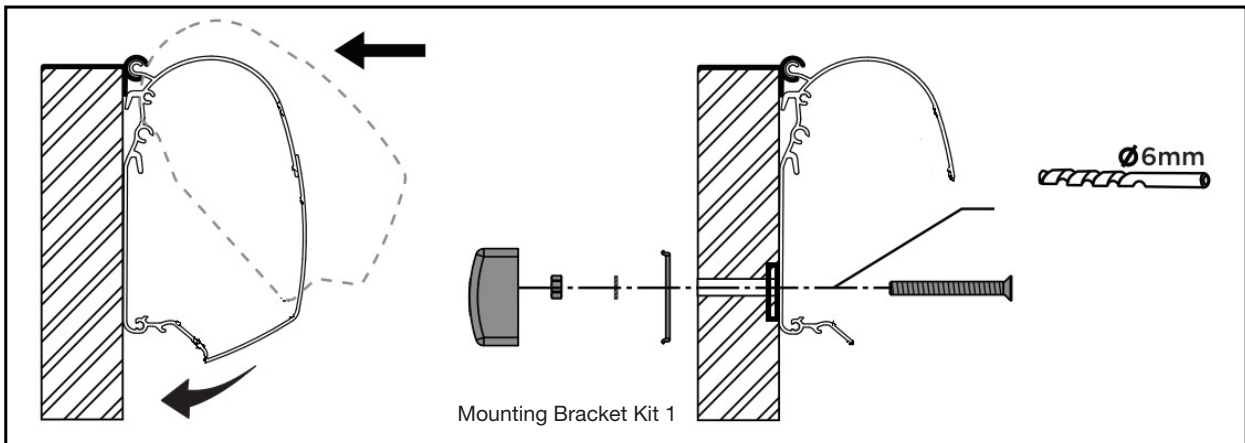

1300 663 868 | [enquiries@aussietraveller.com.au](mailto:enquiries@aussietraveller.com.au) | [aussietraveller.com.au](http://aussietraveller.com.au)

BRISBANE SHOWROOM: 11-15 Oasis Court, Clontarf QLD 4019 | MELBOURNE SHOWROOM: 235 Barry Road, Campbellfield VIC 3061

## WALL MOUNT INSTALLATION (cont.)

### BOTTOM MOUNT AND WINDER HANDLE POSITIONING:

Open the awning to a maximum of 900mm with the winder before engaging awning arms.

To open the awning with the crank handle:

1. Insert winder handle into cassette.
2. Rotate clockwise to open the awning.
3. Rotate anti-clockwise to close the awning.

Where the awning arms meet the caravan, accurately mark the place for the bracket.

1. Screw in lower bracket mount for awning arms.
2. After installing the bracket, insert awning arm feet into the bracket.
3. Make sure the arm is secure.

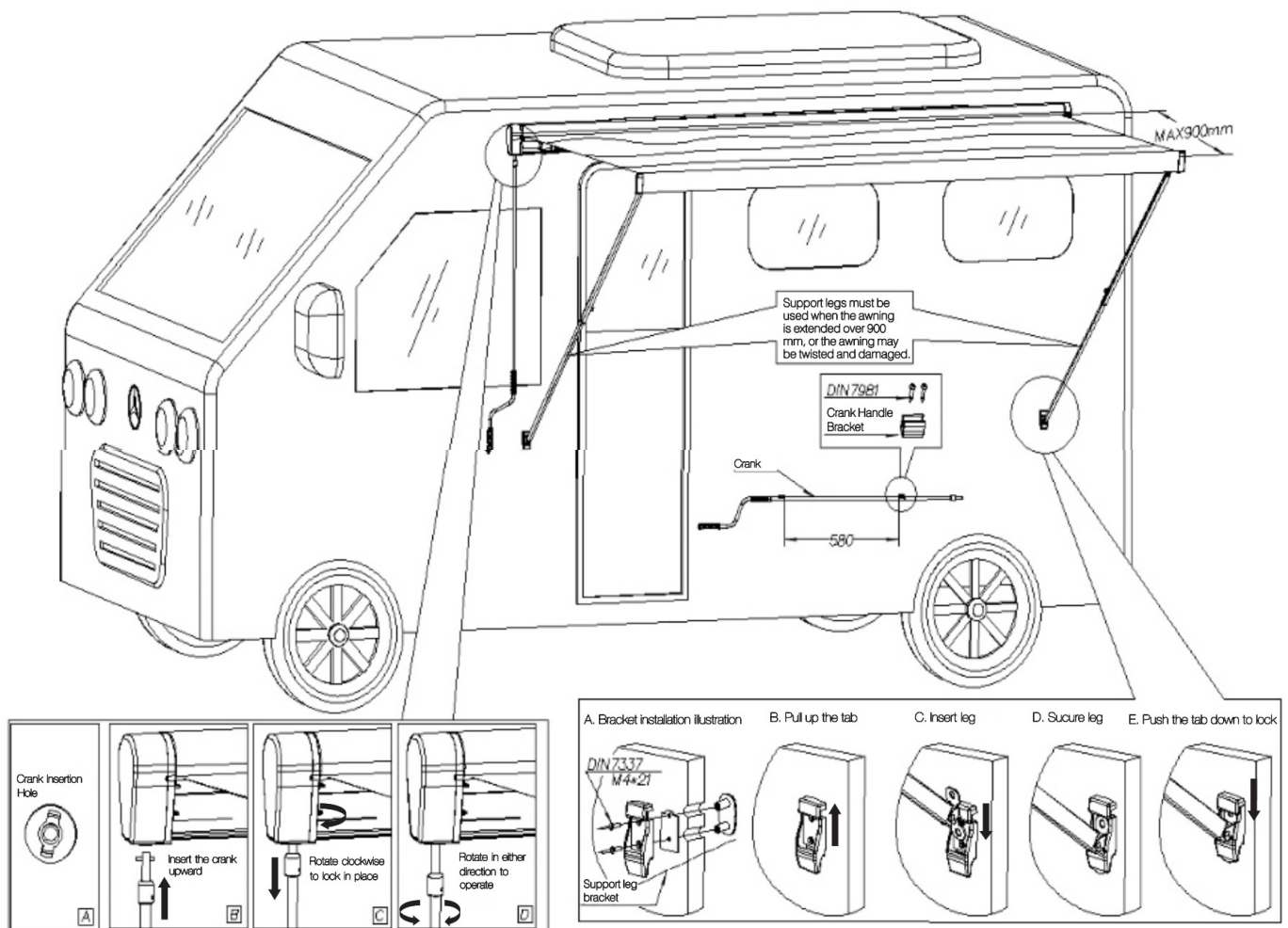

1300 663 868 | enquiries@aussietraveller.com.au | aussietraveller.com.au

BRISBANE SHOWROOM: 11-15 Oasis Court, Clontarf QLD 4019 | MELBOURNE SHOWROOM: 235 Barry Road, Campbellfield VIC 3061

# ROOF MOUNT INSTALLATION

## CORRECT POSITIONING:

When installing the Aussie Traveller Cassette awning follow these instructions for correct installation of the cassette.

- Be sure to install the mounting bracket in the corresponding position of the arm connection block (see image) and ensure all installation brackets are on the same level.
- When the mounting position of awning is not horizontal, please add a gasket between the mounting bracket and the roof, to ensure that the bracket can be installed horizontally and the awning can be opened normally.

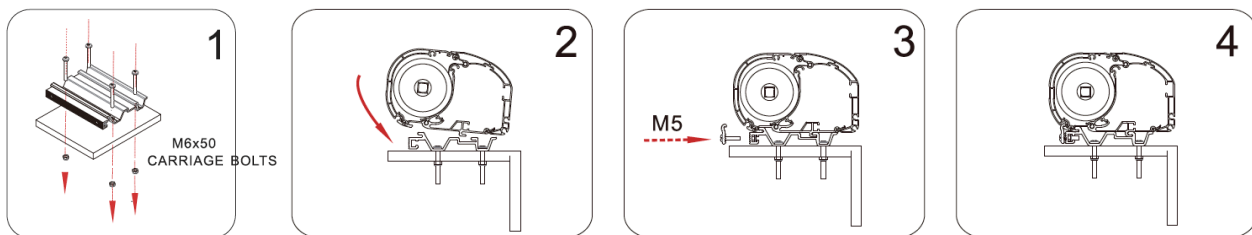
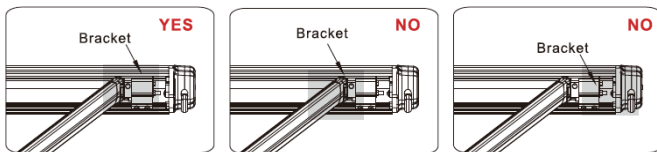

## 12V WIRING:

Please refer to technical drawings on page 8.

- Connect 1 & 4 to motor.
- Connect 2 to the the positive of the power supply.
- Connect 5 & 6 to the negative of the power.

## IMPORTANT:

- Installation must be performed by qualified personnel.
- Check for solid back and ground for installation. The fixing must be with bolts, supports, pegs and support rods. When using pegs or securing items, make sure there are no obstacles (e.g. cables, gas pipes, etc.).
- Installation of awning on any wall surface, the wall surface must be able to support the cassette and extended vinyl. Awnings arms (double swing arm), are to be secured when extended.
- For waterproof installation, use acid-free silicone or sika 252 filled boreholes.
- When drilling or installing, in order not to damage the cloth, the awning is fully expanded, and the surfaces of contact with other objects are padded with cloth.
- For the mounting height of the bottom mounting bracket, ask your dealer or manufacturer.
- The awning is used to cover the sun, not all-weather protection. The awning should be closed when not in use to prevent damage from storms, excessive wind, snow or heavy rain.

1300 663 868 | [enquiries@aussietraveller.com.au](mailto:enquiries@aussietraveller.com.au) | [aussietraveller.com.au](http://aussietraveller.com.au)

BRISBANE SHOWROOM: 11-15 Oasis Court, Clontarf QLD 4019 | MELBOURNE SHOWROOM: 235 Barry Road, Campbellfield VIC 3061

# OPERATING THE CASSETTE AWNING

To operate the Aussie Traveller Cassette Awning:

1. Wind out the awning to maximum 900mm, then drop awning arms.
2. To drop the awning arms:
  - a. Pick up arm from inside the cassette. Lower so it stands vertically.
  - b. Extend the arm to full length and flatten awning arm foot.
  - c. Lock the arm at length by turning to the left.
  - d. Continue to wind out the awning to the open/expanded position required.
3. At maximum expansion, ensure the Aussie Traveller Cassette Awning is secured using awning pegs and guy ropes in adverse conditions - it is recommended you do not extend the awning during adverse wind or rain weather events.

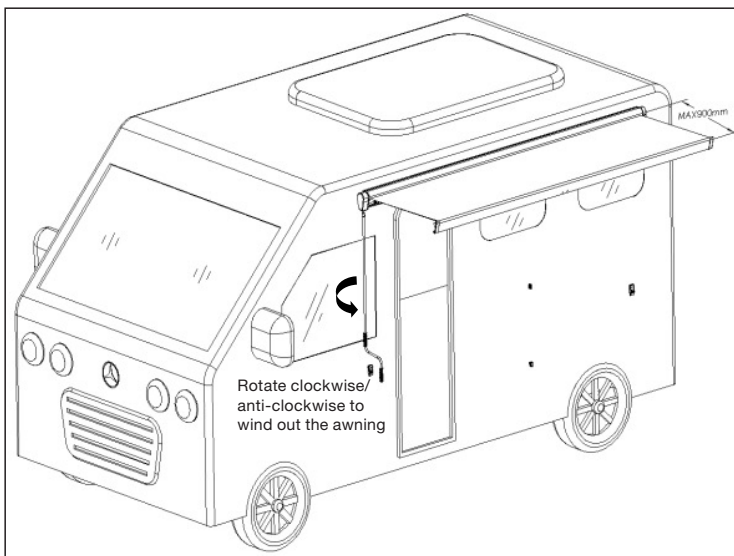

1.

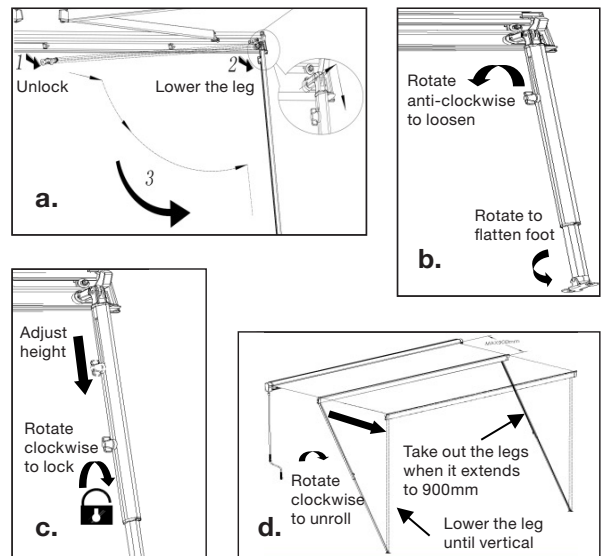

2.

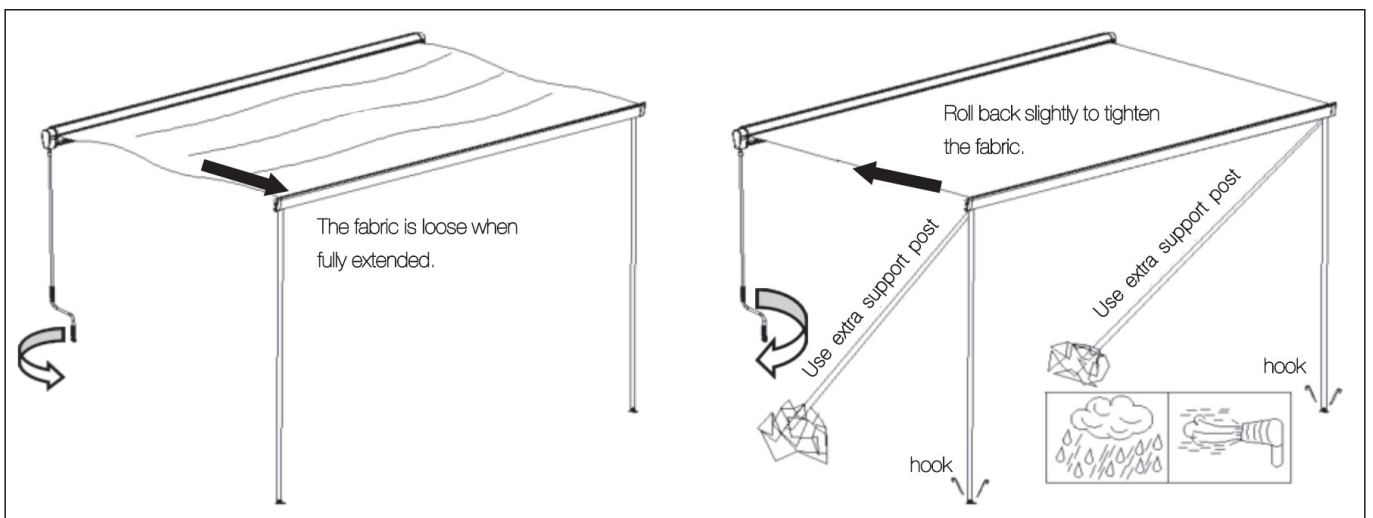

3.

1300 663 868 | [enquiries@aussietraveller.com.au](mailto:enquiries@aussietraveller.com.au) | [aussietraveller.com.au](http://aussietraveller.com.au)

BRISBANE SHOWROOM: 11-15 Oasis Court, Clontarf QLD 4019 | MELBOURNE SHOWROOM: 235 Barry Road, Campbellfield VIC 3061



# TECHNICAL DRAWINGS

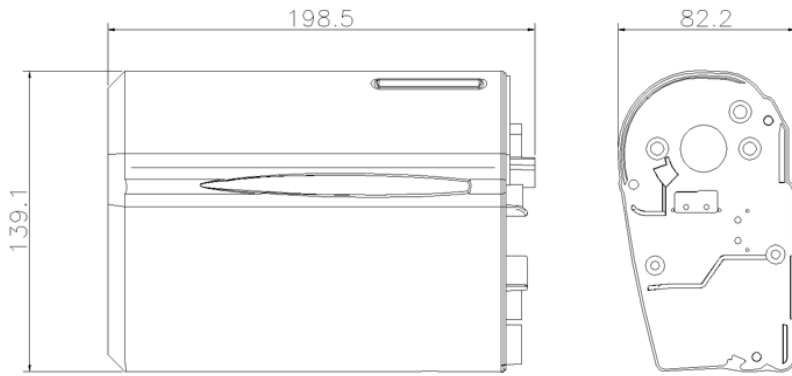

## WIRING DIAGRAM FOR CONTROL PANEL

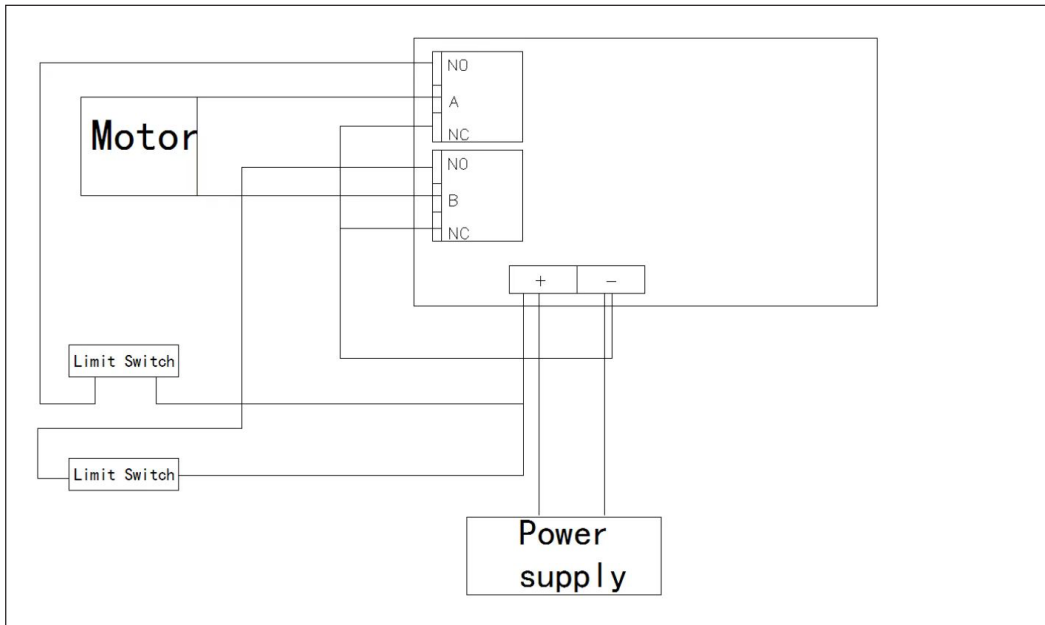

## WIRING DIAGRAM FOR SWITCH

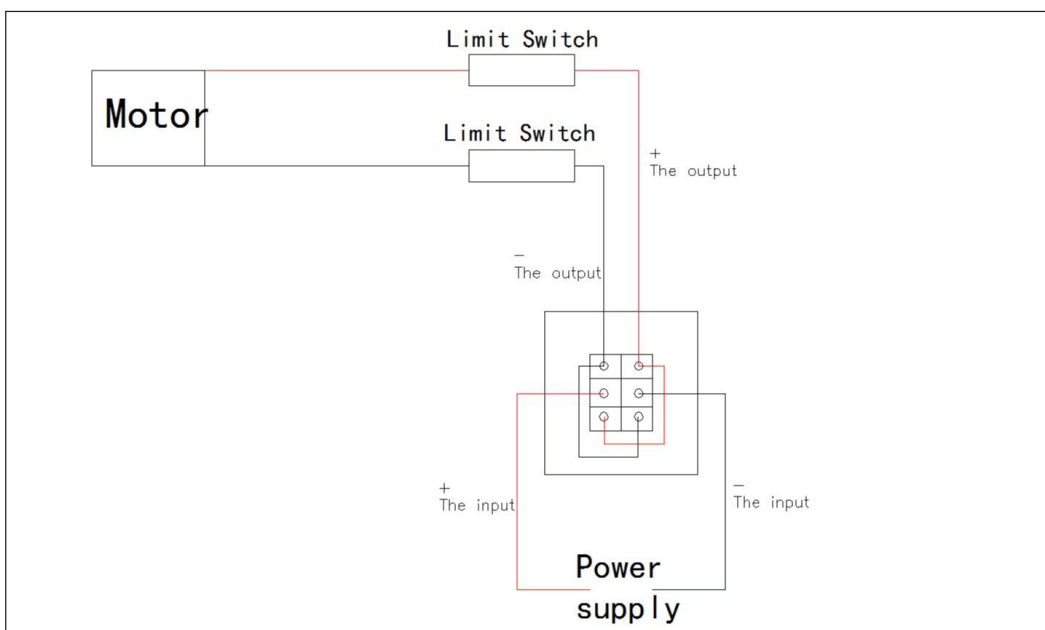

1300 663 868 | [enquiries@aussietraveller.com.au](mailto:enquiries@aussietraveller.com.au) | [aussietraveller.com.au](http://aussietraveller.com.au)

BRISBANE SHOWROOM: 11-15 Oasis Court, Clontarf QLD 4019 | MELBOURNE SHOWROOM: 235 Barry Road, Campbellfield VIC 3061

# WARRANTY STATEMENT

Aussie Traveller Pty Ltd ACN 642 775 460 (**Aussie Traveller**) offers the following warranty in relation to the products it supplies directly or through an authorised manufacturer, dealer or approved service repair agent (**Product**).

## Australian Consumer Law

The benefits of this warranty are in addition to any rights and remedies imposed by Australian State and Federal legislation that cannot be excluded. Nothing in this warranty is to be interpreted as excluding, restricting or modifying any State or Federal legislation applicable to the supply of goods and services which cannot be excluded, restricted or modified.

If you are a consumer as defined in the Australian Consumer Law: *Our goods come with guarantees that cannot be excluded under the Australian Consumer Law. You are entitled to a replacement or refund for a major failure and compensation for any other reasonably foreseeable loss or damage. You are also entitled to have the goods repaired or replaced if the goods fail to be of acceptable quality and the failure does not amount to a major failure.*

## Warranty

Aussie Traveller warrants that, subject to the exclusions and limitations below, all parts of the manufacture and assembly of the Product will be free from defects in materials and workmanship (**Warranty**) for a period of 12 months from the date of purchase as follows:

1. This Warranty is activated at the time of purchase by the final retail customer (being the owner of the Product).
2. In the event the Product is purchased by a manufacturer, dealer or approved service repair agent, this Warranty will commence at the time the final retail customer makes payment for the Product to the wholesale purchaser.
3. If the Product is purchased directly from Aussie Traveller for use by final retail customer and not to be on sold in any way, the Warranty will commence at the time of the original purchase.

## Warranty Period

This Warranty cannot be assigned or transferred to a subsequent owner of the Product.

The purchaser or final retail customer should inspect the Product immediately when received or at vehicle handover, to ensure that it appears free from any damage or defect, and matches the description provided.

If after accepting the Product, a defect appears in the manufacture or assembly of the Product before the end of the Warranty Period and Aussie Traveller finds the Product to be defective in materials or workmanship, Aussie Traveller will, in its sole discretion, either:

- a. replace, repair or refund the Product or the defective part of the Product free of charge; or
- b. cause the Product or the defective part of the Product to be replaced or repaired by a qualified repairer free of charge.

In arranging Warranty inspection, service and repair, Aussie Traveller will seek to provide the details of an approved service agent within your geographic area. Should one not be available, or if the Product is in use in travel, Aussie Traveller reserves the right to seek to arrange a repair or replacement at the next available location on the route of travel.

Aussie Traveller reserves the right to replace defective parts of the Product with parts and components of similar quality, grade and composition where an identical part or component is not available.

Products presented for repair may be replaced by refurbished goods of the same type rather than being repaired. Refurbished parts may be used to repair the Product.

## Aussie Traveller Awning Products

This Warranty covers specified defects in materials or workmanship for Awning Products as follows:

1. The vinyl fabric is warranted against:
  - a. holes caused by mildew (mildew will form on dust and dirt and stain fabric if fabric is not kept clean).
  - b. excessive cracking, peeling, hardening or loss of strength while used under normal conditions.
  - c. excessive fading (a slight colour change may occur due to ultraviolet rays).
2. All hardware components including the roller are warranted not to bend or break under normal use (excluding high winds, water pooling and accidents).

## Making a Warranty Claim

If a defect covered by this Warranty appears, the Customer must first contact Aussie Traveller within 7 days of first becoming aware of the defect. Aussie Traveller will assist the Customer to rectify and resolve any Product issue that may arise.

When making a claim under this Warranty, Aussie Traveller requires that the following information be provided before any further action will be taken.

1. Original Invoice (Document or Number);
2. Make and model of the Product;
3. Make and model of the vehicle (if Product fitted);
4. Vehicle build date (if Product fitted);
5. Vehicle chassis number;

6. Description of damage and/or repair required;
7. Photos of the damage and/or repair; and
8. Appropriate documentation (such as historical and maintenance records).

Aussie Traveller reserves the right to request more information or images should what is provided not be sufficient to make an assessment for the Warranty claim.

The Product must be made available to Aussie Traveller or its authorised repair agent for inspection and testing. If such inspection and testing find no defect in the Product, the final retail customer must pay Aussie Traveller's usual costs of service work and testing.

The final retail customer must bear the cost of the transport of the Product to and from Aussie Traveller or the authorised repair agent, and all insurance of the Product.

## Exclusions

This Warranty will not apply where:

- the Product has been repaired, altered or modified by someone other than Aussie Traveller, or without the written consent of Aussie Traveller or an authorised repair agent;
- the alleged defect in the Product is within acceptable industry tolerances and variances;
- Aussie Traveller cannot establish any fault in the Product after testing and inspection;
- the Product has been used other than for the purpose for which it was designed;
- the alleged defect in the Product has arisen due to the final retail customer's failure to properly use and
- maintain the Product in accordance with any of Aussie Traveller's instructions, recommendations and specifications (including applicable maintenance schedules);
- the alleged defect in the Product has arisen due to the final retail customer's request to customise the Product;
- the Product has been subject to abnormal conditions, including environment, temperature, high or excessive wind, water, fire, humidity, pressure, stress or similar;
- the alleged defect has arisen due to abuse, misuse, neglect or accident;
- unauthorised parts or accessories have been used on or in relation to the Product;
- the Product has been overloaded or involved in an accident;
- the alleged damage or defect has been caused by normal wear and tear;
- the alleged damage to fabric has been caused by storm, wind or rain, or stretching of fabric caused by water pooling on fabric;
- breakage or bending of hardware components has been caused by storm, wind or rain, or water pooling on fabric.

## Replacement Warranty Item

If, under Warranty, a Product is replaced or repaired by Aussie Traveller or an Aussie Traveller agent, unless provided in writing to indicate otherwise, the replacement Product will carry the **remaining** Warranty terms and conditions, including length of time, of the original purchased Product.

## Change of Mind

Aussie Traveller understands that at times, final retail customers may change their mind. Choose carefully as return and credit requests for items purchased by mistake or "change of mind" reasons may not be approved. Aussie Traveller will not accept Product returns under these circumstances unless by written approval by an authorized Aussie Traveller representative. If approved, an administration and restocking fee may apply.

## Limitations

Aussie Traveller makes no express warranties or representations other than set out in this Warranty.

The repair or replacement of the Product or part of the Product is the absolute limit of Aussie Traveller's liability under this express Warranty.

## Contact

**Australia Wide:** 1300 663 868

**Melbourne Office**  
 235 Barry Road  
 Campbellfield, Melbourne, 3061  
 Ph: +61 3 9357 6565  
 enquiries@aussietraveller.com.au

**Brisbane Head Office, Factory & Showroom**  
 11-15 Oasis Court  
 Clontarf, Brisbane, 4019  
 Ph: +61 7 3284 3284  
 enquiries@aussietraveller.com.au

To receive a copy of the Aussie Traveller Warranty Terms & Conditions or information regarding specific Aussie Traveller products, please contact Aussie Traveller Head Office on (07) 3284 3284 or email enquiries@aussietraveller.com.au.